

DAILY 35S13



PRODUCTIVITY

- FUEL TANK SETUP READY FOR BODYBUILDERS
- HANDSFREE AND BLUETOOTH PHONE CAPABILITIES
- FLAT, NON-RIVETED CHASSIS
- 40,000 KM ENGINE OIL INTERVALS



SAFETY

- STABILITY CONTROL
- DRIVER, PASSENGER AND CURTAIN AIRBAGS
- HILL HOLDER
- TRAILER SWAY MITIGATION
- FRONT AND REAR DISC BRAKES



STRENGTH

- SOLID STEEL C-SECTION TRUCK CHASSIS
- HEAVY DUTY CROSS MEMBERS
- HIGH AXLE CAPACITIES



COMFORT

- INDEPENDENT FRONT SUSPENSION WITH TORSION BAR
- PARABOLIC REAR SUSPENSION
- STANDARD SEATS
- CAR LIKE DRIVEABILITY



VERSATILITY

- OPTIONAL AUTOMATIC TORQUE CONVERTER TRANSMISSION
- FACTORY FITTED BODY MOUNTS
- OPTIONAL DRIVER CONTROLLED DIFF LOCK
- OPTION OF ELECTRONICALLY CONTROLLED REAR AIR SUSPENSION

*Overseas model Daily cab chassis shown with optional tray and alloy wheels.



PERFORMANCE

3.0 LITRE TURBO DIESEL ENGINE

UP TO 205 HP AND 347 LB FT OF TORQUE

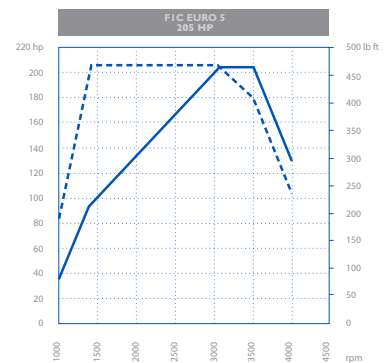
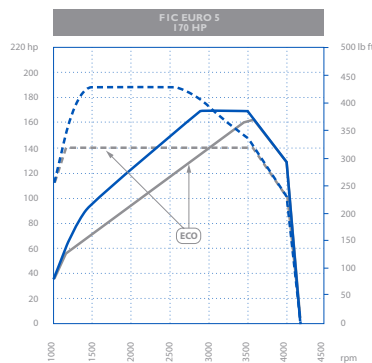
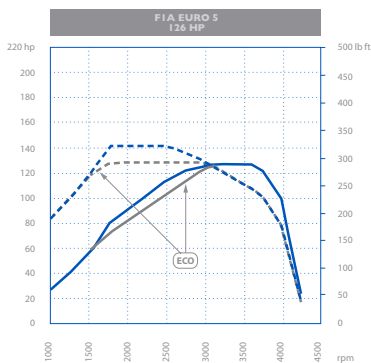

ENGINE

126 hp: IVECO FIA (EURO 5) – 4 stroke diesel with direct-injection, turbocharger with wastegate and intercooler

Optional: 170 hp: IVECO FIC (EURO 5) – 4 stroke diesel with direct-injection, Variable Geometry Turbocharger (VGT) and intercooler.

205 hp: IVECO FIC (EURO 5) – 4 stroke diesel with direct-injection, Twin Stage Turbo (TST) and intercooler.

Maximum Output: 126 hp/93 kW @ 3000-3600 rpm
170 hp/125 kW @ 2900-3500 rpm
205 hp/150 kW @ 3100-3500 rpm

Maximum Torque: 236 lb ft/320 Nm @ 1800-2500 rpm
317 lb ft/430 Nm @ 1650-2500 rpm
347 lb ft/470 Nm @ 1400-3000 rpm

Emissions Technology: Exhaust Gas Recirculation system

Total Displacement: FIA: 2.3 litre
FIC: 3.0 litre

Exhaust: Muffler horizontally positioned on the right side and tailpipe located mid-way down right side of vehicle

DAILY 35S13

DIMENSIONS (mm)

X	Wheelbase	3450	3750
K	Overall length	5913	6523
H	Overall height <i>unladen</i>	2239	2220
	Front track	1740	1740
	Rear track	1704	1704
T	Unladen frame height at end of frame	697	697
	Front ground clearance	143	143
	Rear ground clearance	180	180
Y	Rear overhang	1455	1765
	Turning circle: kerb to kerb	11876	12764
	Turning circle: wall to wall	12536	13428

BODY DIMENSIONS (mm)

Maximum body width	2010	2010
--------------------	------	------

MASS (kg)

GVM	3500	3500
GCM	7000	7000
Front axle capacity	1900	1900
Rear axle capacity	2240	2240
Kerb mass front axle	1327	1335
Kerb mass rear axle	450	457
Kerb mass total	1777	1792
Payload capacity	1723	1708

Kerb masses are with minimal fuel, spare wheel, tools and no driver.

FRONT AXLE & SUSPENSION

- Mecbal front axle

Capacity: 1900 kg

Suspension Type: Mechanical transversal leaf suspension

Capacity: 1900 kg

REAR AXLE & SUSPENSION

- NDA RS rigid axle

Capacity: 2240 kg

Suspension Type: Parabolic single leaf spring suspension

Capacity: 2240 kg

Rear axle ratio: 126 hp - 3.60 manual and automatic transmission

170 hp - 3.60 manual and 3.31 automatic transmission

205 hp - 3.7 manual and 3.31 automatic transmission

BRAKES

Type: ABS + ASR 9 with EBD (Electronic Brake force Distribution) and Hill Holder

Front / Diameter: Ventilated disc brakes / 300 mm (28 mm thick)

Rear / Diameter: Disc brakes / 296 mm (16 mm thick)

Parking brake: Manual brake operating on rear axle

Service brakes: Dual circuit with vacuum servo

- Pad wear warning light for front and rear brakes

ESP – Electronic Stability Programme

Programme: (includes ASR – Anti Slip Regulator or Traction Control, HBA – Hydraulic Brake Assist, Hill Holder, LAC – Adaptive Load Control, TSM – Trailer Sway Mitigation, HRB – Hydraulic Rear Wheel Boost, HFC – Hydraulic Fading Compensation, RMI and ROM – Roll Movement Intervention and Roll Over Mitigation)

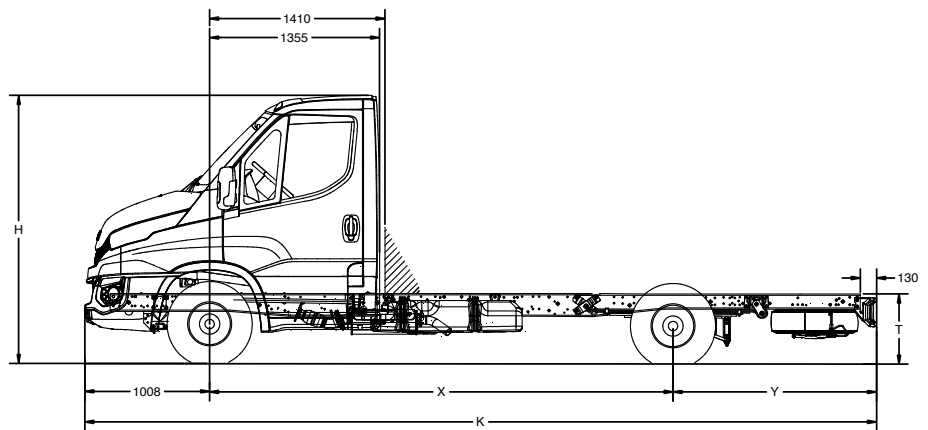

STEERING

- Power steering
- 390 mm diameter steering wheel with telescopic adjustment

FUEL SYSTEM

- 70 litres with fuel cap location on passenger side

TRANSMISSION

- Six speed synchromesh double overdrive manual

Type: 2835.6 OD

1st 5.004, 2nd 2.635, 3rd 1.503, 4th 1.000 OD, 5th 0.812, 6th 0.701 DOD, Rev.4.506

- 8 Speed ZF Torque Converter Automatic (Hi-Matic)

Type: 8V470A

1st 4.696, 2nd 3.130, 3rd 2.104, 4th 1.667, 5th 1.285, 6th 1.000, 7th 0.839 OD, 8th 0.667 DOD, Rev. 3.297

CLUTCH

- Single dry plate
- Hydraulically controlled

Diameter: 267 mm

CHASSIS

Type: C Section steel longitudinal side members with tapered ends and tubular cross members

ELECTRICAL SYSTEM

Battery: 12 Volt – 110 Ah

Smart Alternator: 12 Volt – 180 A

- Trailer wiring to rear of chassis

WHEELS & TYRES

Wheels: Steel 5J x R16

Tyres: 225/65 R16

CABIN FEATURES

- Driver, passenger and curtain airbags with seat belt pretensioners
- Standard seats
- Dual bench passenger seats with headrests
- Electric windows
- Exterior mirror with integrated wide angle and direction indicators, heated and electronically adjustable
- Overhead console with storage shelf and space for additional equipment
- Large dual storage pockets in doors
- Document storage compartment
- Body builder connections

- Additional in-dash storage
- Automatic climate control
- Daytime running lights

DASHBOARD

- Analogue electronic speedometer
- Fuel level indicator with reserve light indicator
- Coolant temperature indicator with high temperature indicator light
- Instrument light dimmer switch
- Dash-mounted gear lever
- 3 storage areas on top of dash
- LCD Display Panel includes: odometer, trip computer with distance, time, fuel consumption etc; headlamp orientation, clock, speed limit exceeding, external temperature and service indicator
- IVECONNECT multimedia 7" touch screen with CD/MP3 player, iPod compatible, Bluetooth and SD card reader
- Multifunction steering wheel

SECURITY

- Central locking with remote control
- Steering lock

OPTIONS

- Heated and suspended driver's seat and single passenger seat

IVECO

Your partner for sustainable transport